

UHF Narrow band radio data module CDT-TX-02M 434 MHz



Operation Guide Version 3.0 (Oct. 2023)

- This product requires electrical and radio knowledge for setup and operation.
- To ensure proper and safe operation, please read this operation guide thoroughly prior to use.
- Please keep this operation guide for future reference.

CIRCUIT DESIGN, INC.

7557-1 Hotaka, Azumino
Nagano 399-8303 JAPAN
Tel: + +81-(0)263-82-1024
Fax: + +81-(0)263-82-1016

e-mail: info@circuitdesign.jp
<http://www.circuitdesign.jp>

CONTENTS

Outline	3
Features	3
Application examples	3
Main Specifications.....	4
Block diagram.....	5
Dimensional drawing	6
PCB mounting hole dimensional drawing	7
Functions of each part.....	8
Explanation of the terminals	9
Selecting frequency channels	10
Connection method	10
Time from switch input until output.....	11

Outline

The CDT-TX-02M is an integrated wireless transmitter module for telecontrol applications. By combining with the receiver module CDT-RX-02M-R or CDT-RX-03M, you can easily achieve a telecontrol device that can send and receive six contact switch signals. MSK modulation and highly sensitive reception performance enable a communication range of 500 m or more.

You can choose from four frequency channels. By setting each unit to a different channel, you can use up to four systems within the same area simultaneously.

You can register the IDs of up to 100 transmitters in the receiver.

The output port of the receiver uses photo MOSFET output, enabling direct drive of relays. The output control mode can be set to four modes. You can meet the requirements of a variety of applications by setting the mode accordingly.

Features

- Four selectable frequency channels.
- Six input contacts for communication
- You can register the IDs of up to 100 transmitters in the receiver
- Low voltage, low consumption current operation
- Compact size
- RoHS / RED compliant

Application examples

- Calling systems
- Signaling systems for construction sites and industrial plants
- Electric shutter control
- Warning systems
- Switching device for LED display panel

Main Specifications

CDT-TX-02M

Item	Specification	Remarks
Compatible standards	EN 300 220	
Frequency channels	434.075/433.920/434.600/434.700 MHz	Selected with DIP switches
Communication method	One-way communication	
Modulation	Sub-carrier MSK	
Bit rate	1,200 bps	
Oscillation system	PLL-controlled VCO	
Transmission output	10 mW or less	
Operating voltage	DC 2.2 to 12 V	Maximum rating: DC 14.5 V
Current consumption	Transmitting: 27 mA Standby: 1 μ A	
Input ports	SW1 to SW6 (6 inputs)	Negative logic (active Low)
Connection terminals	VCC, GND (2 terminals) SW1 to SW6 (6 terminals)	
DIP switches (2 circuits)	You can set four different frequency channels	
Antenna	Lead antenna Antenna length: Approx. 175 mm (quarter-wave)	
Operating temperature range	-20 to +60 °C	No condensation (non-waterproof, non-dustproof spec)
External dimensions	36 × 26 × 8 mm	Not including projecting parts and the antenna
Weight	Approx. 15 g	

Reference:

Communication range: 500 m to 800 m (line-of-sight, installation height 1.5m, communication with CDT-RX-02M-R or CDT-RX-03M)

Block diagram

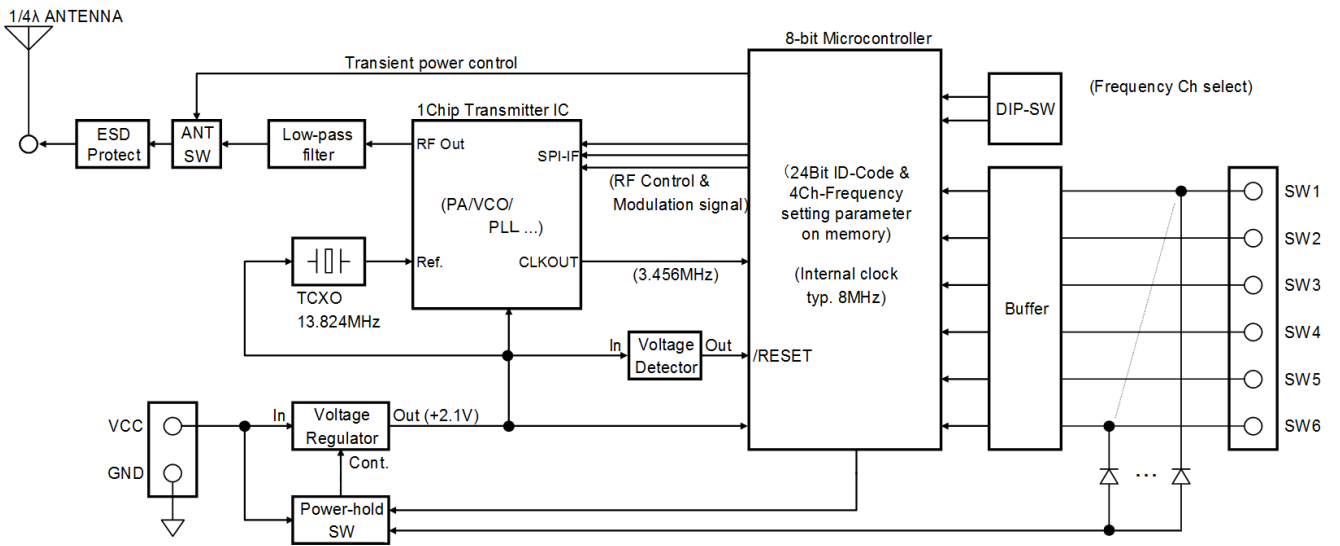

Dimensional drawing

CDT-TX-02M

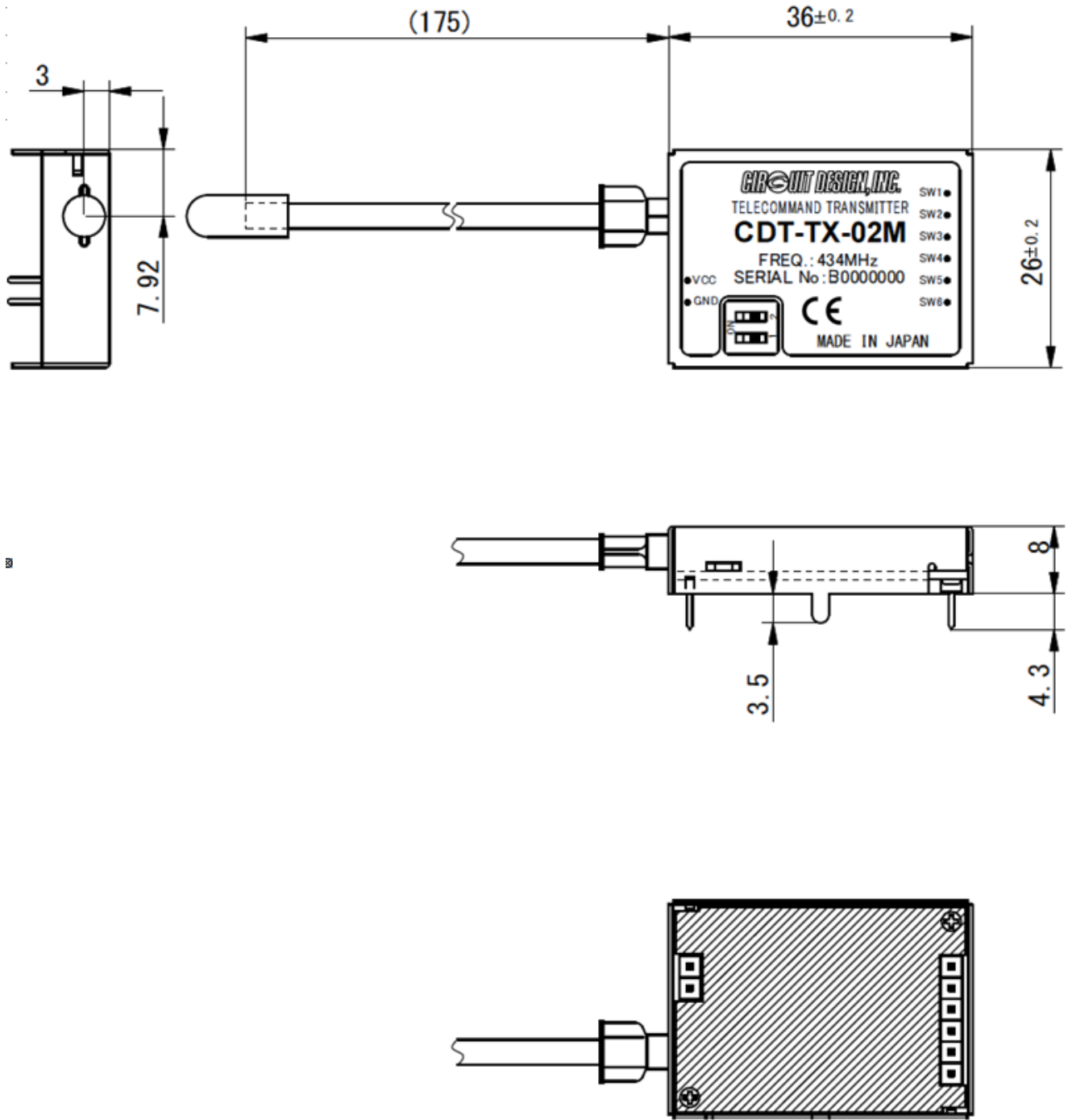

PCB mounting hole dimensional drawing

Recommended dimensions for the PCB mounting holes. Positions of the holes viewed from the mounting surface side of the module.

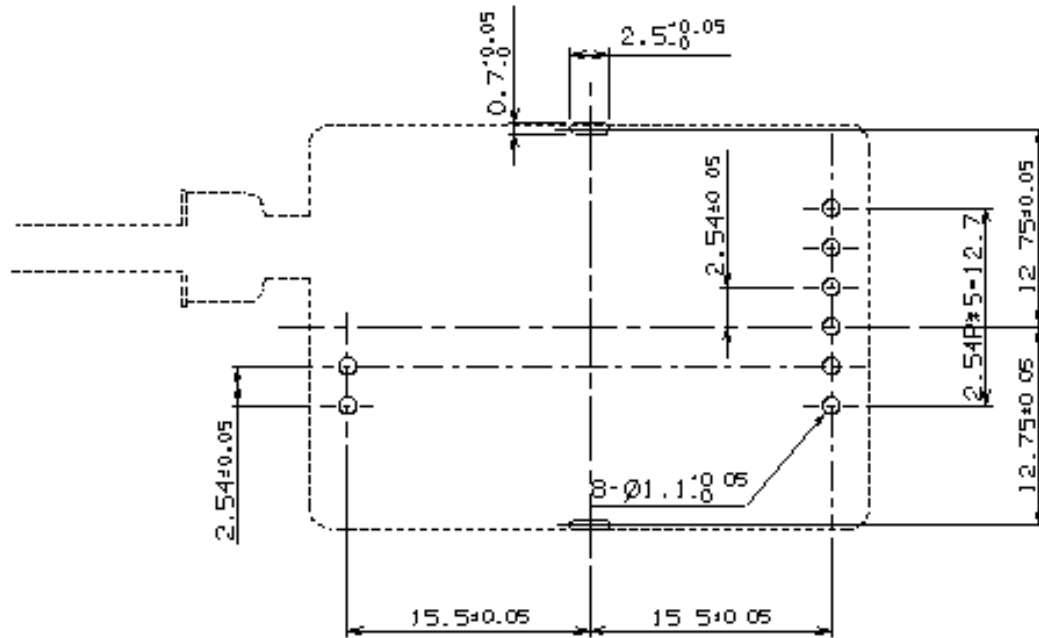

Functions of each part

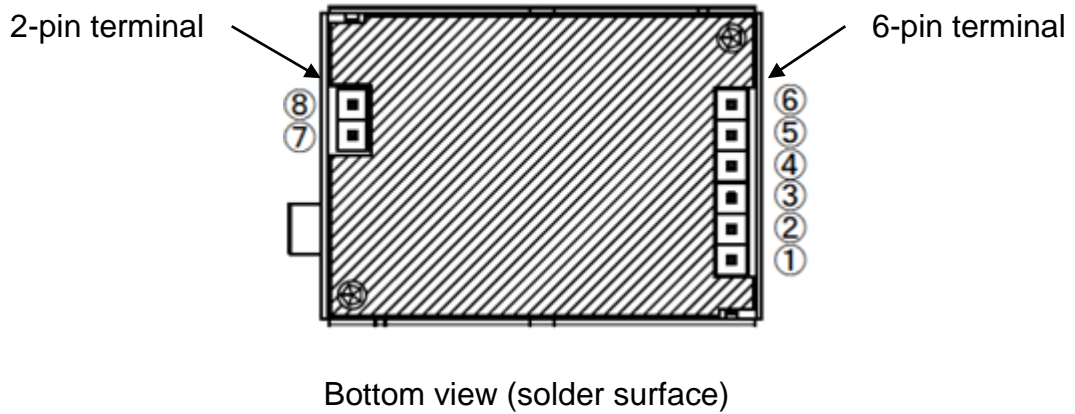
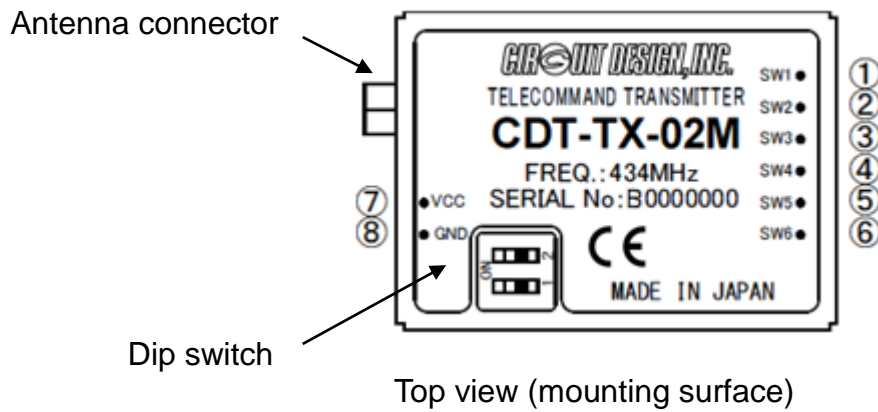

* See page 9 for a detailed explanation of each terminal (1 to 8).

Antenna connector	RF output terminal (50 Ω impedance)
DIP switches	For selecting frequency channels: 2 circuits
6 pin terminals: 1 to 6	Terminals for external connections: SW1 to SW6
2 pin terminals: 7 and 8	Power terminals: VCC, GND

Explanation of the terminals

No.	Terminal name	Input/output	Description	Internal equivalent circuit
1 to 6	SW1 to 6	Input	<p>Switch input. SW1 to SW6 are the same specification.</p> <p>When GND is connected to any of SW1 to SW6, the unit transmits data.</p> <p>When the input of all switches is set to open, the unit enters standby mode.</p> <p>If the wiring to the input is long, noise may occur and cause malfunction. Measures such as adding a separate circuit are required.</p> <p>If chattering occurs, take measures such as adding capacitors.</p>	
7	VCC	Input	<p>The power supply positive terminal.</p> <p>Operates in a range from 2.2 to 12 V.</p> <p>Avoid reverse connection to the power supply and overvoltage. They may damage the circuit.</p> <p>Connect a 10 μF electrolytic capacitor between the VCC terminal and ground of the module.</p>	
8	GND	Input	<p>The power supply negative terminal.</p> <p>Connect with the ground on the printed circuit board.</p> <p>The ground serves both as the input for the power supply and the antenna radial.</p> <p>In order to increase the efficiency of the antenna and achieve stable operation, provide as large a ground pattern as possible.</p>	

The antenna

- The antenna is quarter-wave for maximum radiation.
- We recommend using the antenna supplied (ANT-LEA-01) or an antenna with equivalent characteristics. If you use an antenna other than the recommended antenna, the unit may no longer comply with the regulations.
- The antenna is a lead type, designed for integration in other equipment. If the transmitter is enclosed in a metal case, it will not be able to emit radio waves. Be sure to use plastic or other casing. Design your equipment so that the antenna is located as far as possible from metal objects (such as the shielding case of the transmitter and printed circuit board).

Selecting frequency channels

- When you turn on the power of the CDT-TX-02M, it checks the status of the DIP switches of each unit to determine the frequency to use.
You can set four different frequency channels shown in the table below using the DIP switches.
- By setting each unit to a different frequency, you can use up to four systems within the same area simultaneously.

DIP switch settings		Frequency channels MHz	Default (factory) setting
SW2	SW1		
OFF	OFF	434.075 MHz	●
OFF	ON	433.920 MHz	
ON	OFF	434.600 MHz	
ON	ON	434.700 MHz	

Connection method

CDT-TX-02M transmitter basic connection diagram

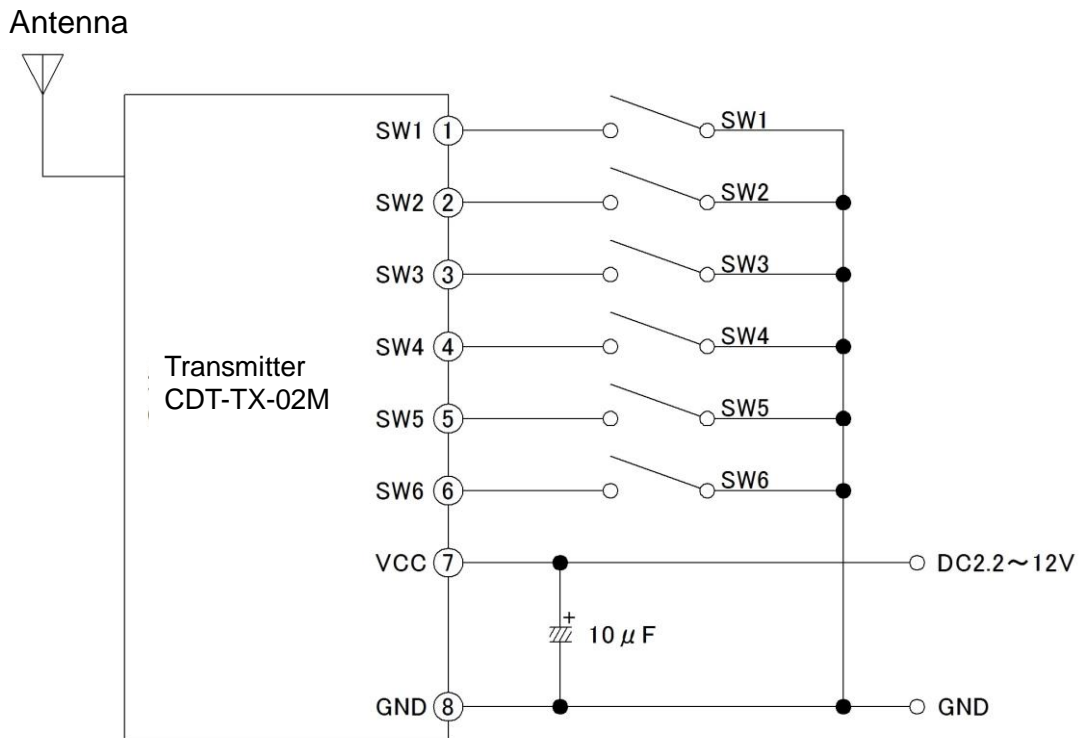

- When the wiring to the SW1 to SW6 inputs is long, measures such as adding a separate circuit may be required.
- If the switches connected to the SW1 to SW6 cause chattering, add capacitors between the switches to prevent malfunction.

Time from switch input until output

This section describes the timing information related to switch input and output when the CDT-TX-02M is used with the CDT-RX-02M-R or CDT-RX-03M receiver.

- **Time between switch input and start of transmission with CDT-TX-02M**
It takes about 50 ms from switch input until the start of transmission

Data transmission starts about 50 ms after switch input is set to on. The data is sent frame by frame, and it takes 63 ms to send one frame, including the on and off signals.

- **When reception is good**
It takes about 113 ms from setting the transmitter switch input to on until the start of output from the receiver.

When the transmission data on signal has been received in the first frame, the time it takes from setting the transmitter switch input to on until the start of output from the receiver is about 113 ms at the shortest. The time until the start of output is the same for all output control modes (one-shot, toggle, switching, continuous).

When radio conditions are good and the first frame of data has been received

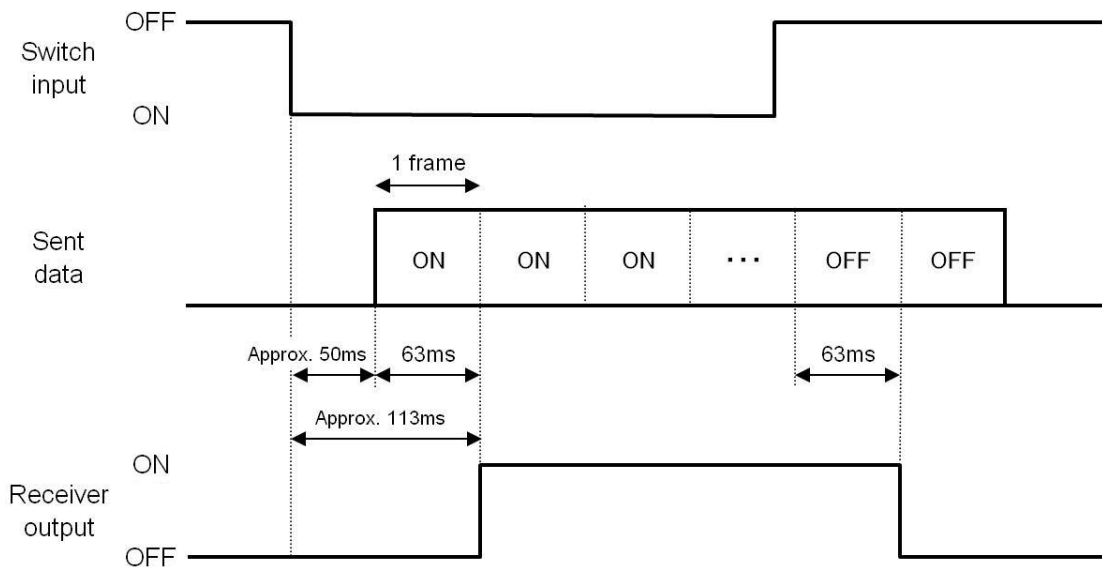

For details of the input/output timing, also refer to the operation guide of the CDT-RX-02M-R or CDT-RX-03M.

- Explanation of each output control mode
- Time from switch input until output

Regulatory compliance information

Declaration of Conformity

Hereby, Circuit Design, Inc. declares that the CDT-TX-02M is in compliance with RE Directive (2014/53/EU). The full text of the EU Declaration of Conformity is available at www.circuitdesign.jp.

Cautions related to regulatory compliance when embedding the CDT-TX-02M

1. Duty cycle

The CDT-TX-02M are designed to be used in the EU wide harmonised frequency bands for short range devices. The user must design the final product to meet the relevant duty cycle requirement (For more details, refer to the EN300 220).

2. Antenna

The conformity assessment of the CDT-TX-02M was performed using Circuit Design's standard antenna ANT-LEA-01 (1/4 lambda lead antenna), so we recommend using the ANT-LEA-01 antenna or an antenna with equivalent characteristics (2.14 dBi or less). For details about our standard antenna, refer to www.circuitdesign.jp or contact us. If you use an antenna other than the recommended antenna, further radio conformity assessment may be required.

3. Supply voltage

The CDT-TX-02M should be used within the specified voltage range (2.2 V to 12.0 V).

4. Enclosure

To fulfill the requirements of EMC and safety requirements, the CDT-TX-02M should be mounted on the circuit board of the final product and must be enclosed in the case of the final product. No surface of the module should be exposed.

Conformity assessment of the final product

The manufacturer of the final system needs to conduct full EMC testing in the final configuration and also ensure the final product fulfills the health and safety requirements and is also responsible for the conformity assessment procedures of the final product in accordance with the RE Directive.

Important notice

- Customers are advised to consult with Circuit Design sales representatives before ordering. Circuit Design believes the provided information is accurate and reliable. However, Circuit Design reserves the right to make changes to this product without notice.
- Circuit Design products are neither designed nor intended for use in life support applications where malfunction can reasonably be expected to result in significant personal injury to the user. Any use of Circuit Design products in such safety-critical applications is understood to be fully at the risk of the customer and the customer must fully indemnify Circuit Design, Inc for any damages resulting from any improper use.
- As the radio module communicates using electronic radio waves, there are cases where transmission will be temporarily cut off due to the surrounding environment and method of usage. The manufacturer is exempt from all responsibility relating to resulting harm to personnel or equipment and other secondary damage.
- The manufacturer is exempt from all responsibility relating to secondary damage resulting from the operation, performance and reliability of equipment connected to the radio module.

Copyright

- All rights in this operation guide are owned by Circuit Design, Inc. No part of this document may be copied or distributed in part or in whole without the prior written consent of Circuit Design, Inc.

Cautions

- Do not use the equipment within the vicinity of devices that may malfunction as a result of electronic radio waves from the radio module.
- Communication performance will be affected by the surrounding environment, so communication tests should be carried out before actual use.
- Ensure that the power supply for the radio module is within the specified rating. Short circuits and reverse connections may result in overheating and damage and must be avoided at all costs.
- Ensure that the power supply has been switched off before attempting any wiring work.
- The case is connected to the GND terminal of the internal circuit, so do not make contact between the '+' side of the power supply terminal and the case.
- When batteries are used as the power source, avoid short circuits, recharging, dismantling, and pressure. Failure to observe this caution may result in the outbreak of fire, overheating and damage to the equipment. Remove the batteries when the equipment is not to be used for a long period of time. Failure to observe this caution may result in battery leaks and damage to the equipment.
- Do not use this equipment in vehicles with the windows closed, in locations where it is subject to direct sunlight, or in locations with extremely high humidity.
- The radio module is neither waterproof nor splash proof. Ensure that it is not splashed with soot or water. Do not use the equipment if water or other foreign matter has entered the case.
- Do not drop the radio module or otherwise subject it to strong shocks.
- Do not subject the equipment to condensation (including moving it from cold locations to locations with a significant increase in temperature.)
- Do not use the equipment in locations where it is likely to be affected by acid, alkalis, organic agents or corrosive gas.
- Do not bend or break the antenna. Metallic objects placed in the vicinity of the antenna will have a great effect on communication performance. As far as possible, ensure that the equipment is placed well away from metallic objects.
- The GND for the radio module will also affect communication performance. If possible, ensure that the case GND and the circuit GND are connected to a large GND pattern.

Warnings

- Do not take apart or modify the equipment.
- Do not remove the product label (the label attached to the upper surface of the module.) Using a module from which the label has been removed is prohibited.

Copyright 2023, Circuit Design, Inc.

REVISION HISTORY

Version	Date	Description	Remark
1.0	June 2011	First created	
1.1	Sept. 2011	DOC added	
1.2	Feb. 2014	DOC updated	
1.3	Sept. 2015	Correction of erroneous description, DOC update	
2.0	Aug. 2017	Update according to RED requirements	
3.0	Oct. 2023	Revised as CDT-TX-02M operation guide	